

MANUAL FOR PATTERN DRILLER

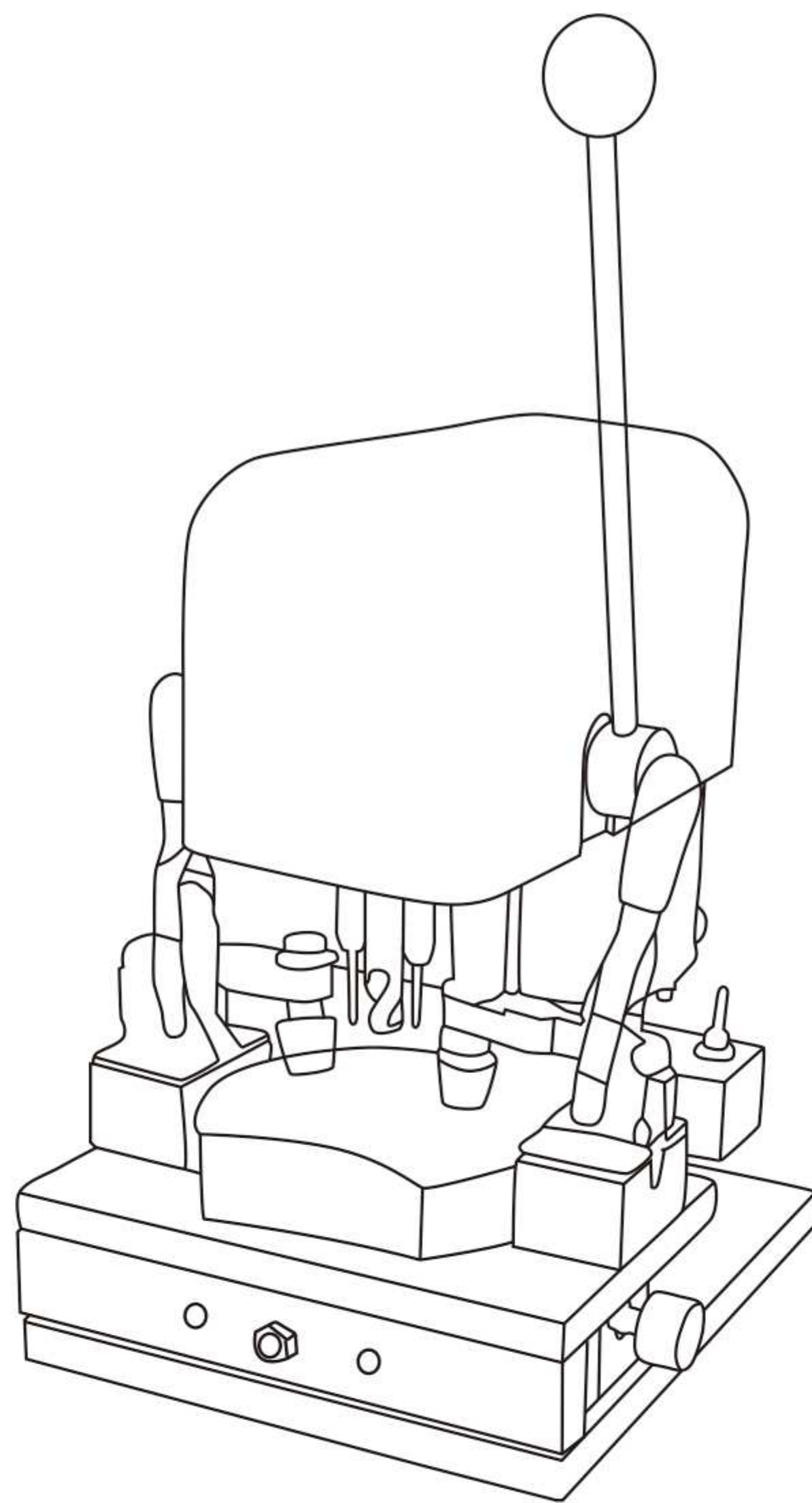

- 1、 Loosen the fixing lock.
- 2、 Slide out the operation plate smoothly and fix the lock.
- 3、 Locate the pattern onto the scale. View vertically to make sure the axis and the optical center are in right positions.
- 4、 Press down the fixing bar, hold the pattern tightly.
- 5、 Loosen the fixing lock, push back the operation panel to the bottom and fix the lock.
- 6、 Turn on the main power switch, press the drilling handle gently to drill.
- 7、 This device must be connected to the ground.

Features:

Metal body, powerful motor, clear scale and high precision.

Content:

	Name	Qty	Remarks
1	Main body	1pc	
2	Brush	1pc	For cleaning
3	Belt	2pcs	For maintenance
4	Small bit	2pcs	For maintenance
5	Drilling handle	1pc	Main part
6	Internal hexagonal wrench	1pc	For precision adjusting
7	SS pattern	5pcs	For pattern enhancing
8	Carbon brush	2pcs	For maintenance
9	Desiccant	1pc	
10	Warranty card	1pc	
11	Manual	1pc	

MANUAL FOR PATTERN DRILLER

Thank you for using this machine. This machine is used to drill the pattern or demo of the lenses. Please follow the instructions below for better processing.

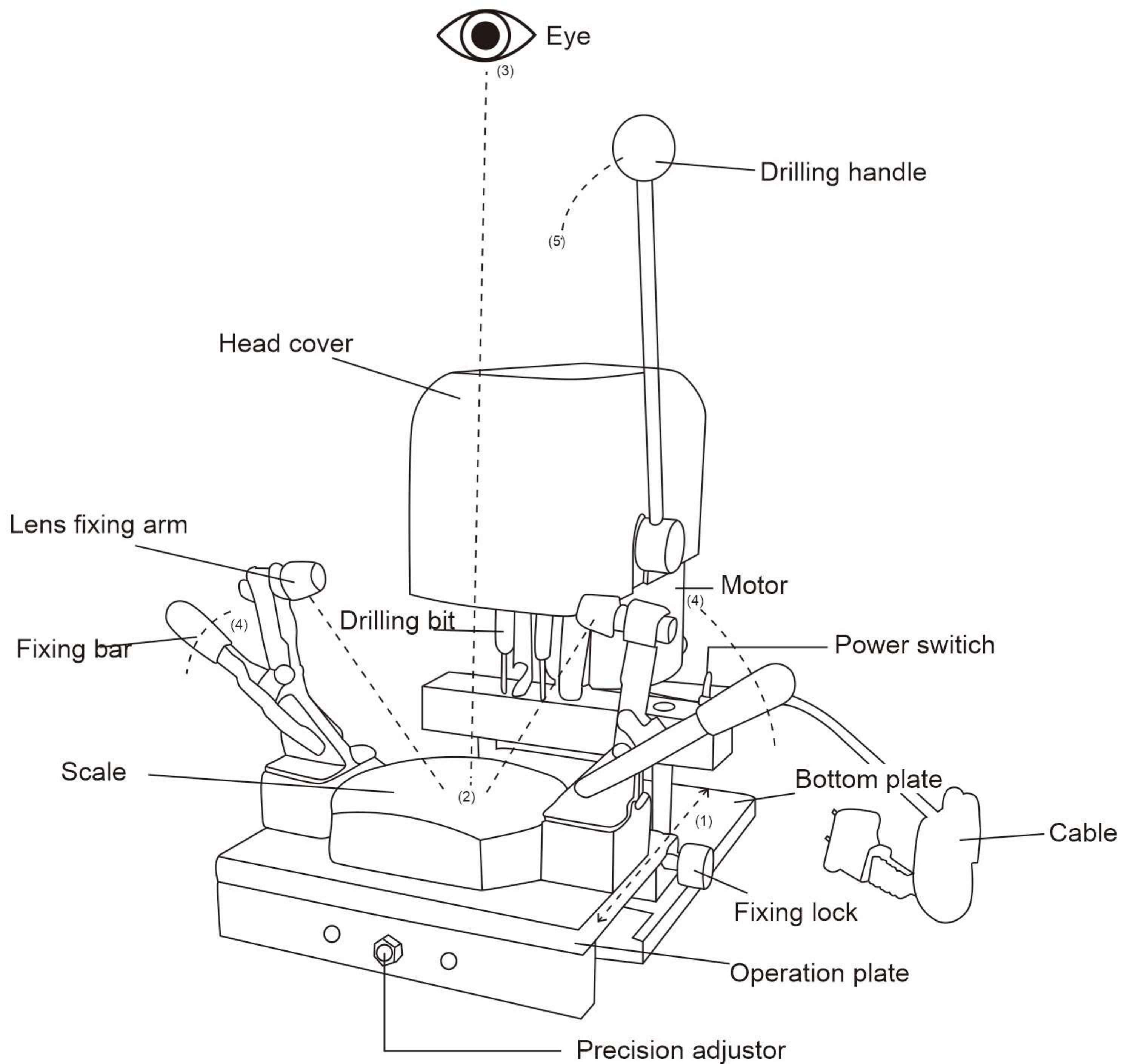

Note: Dotted lines are operation tracks.